

SRS08 single-stage hermetic Compressor

srmtecgroup.com/products/compressors/srs-08 HT/

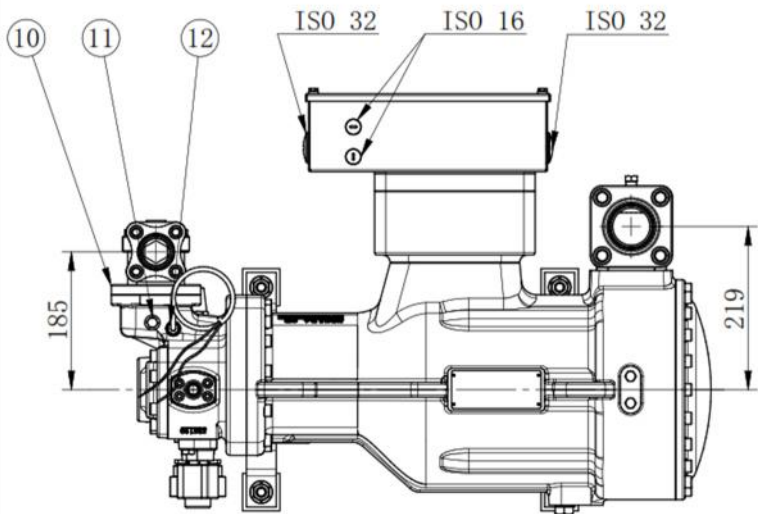

SRS08 HT Series		
Model	SRS-08SL	SRS-08ML
Displacement @2960 rpm [m3/h]	85	100
Displacement @3600 rpm [m3/h]	102	119
Capacity Control	Steps 50%-75%-100%	
Max. rpm	3600	
E-motor (kW)	27	33
Vi Control	Fixed	
Vi adjustment range	2,6	2,6
Rotation, onto compressor shaft	counter-clockwise, looking at the compressor input shaft	
Non-return valve discharge side	Yes	
Suction inlet diameter [mm]	OD 60,3; DN50	
Discharge outlet diameter [mm]	OD 42,4; DN32	
Eco connection [mm]	OD 22; DN15	
Design pressure	28 bar	
Length [mm]	804	877
Width [mm]	380	370
Height [mm]	374	374
Weight [kg]	190	200

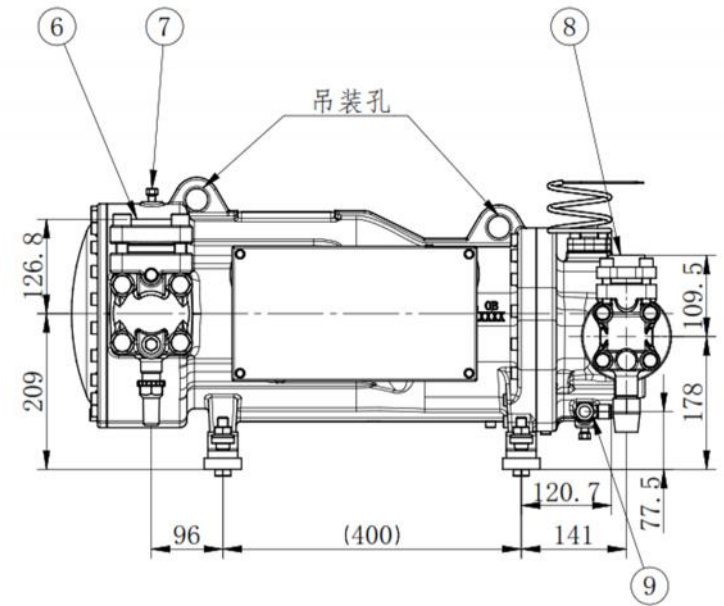
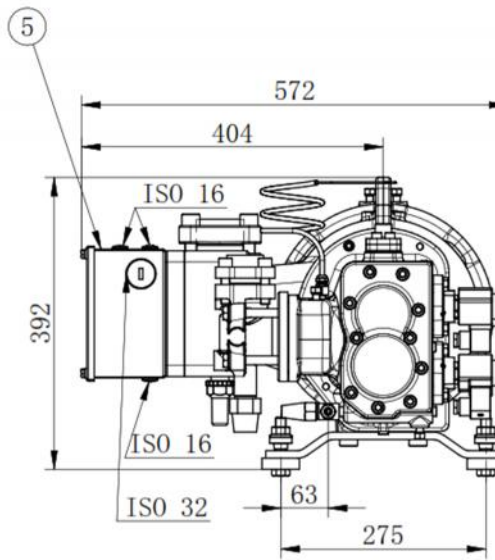
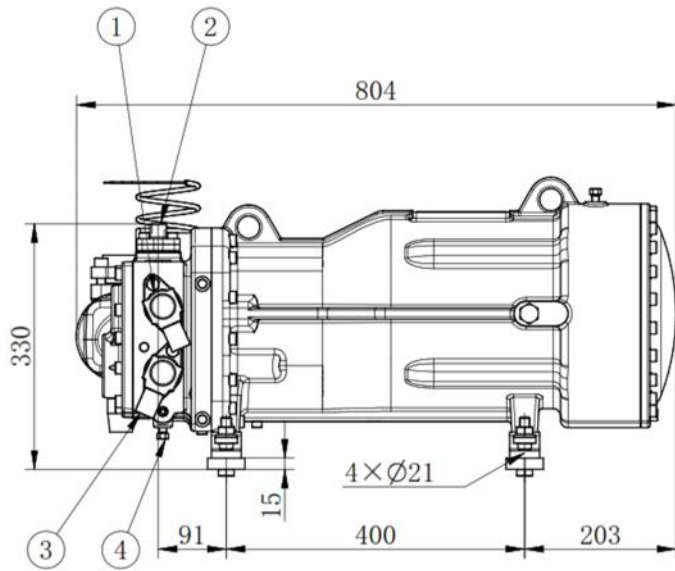

KEY:

- 1、 75% load solenoid valve
- 2、 Economiser Ø16
- 3、 50% load Solenoid valve
- 4、 Oil pressure 1/8"NPT
- 5、 Electrical box
- 6、 Suction shut-off valve Ø58
- 7、 Low pressure gas 1/8"NPT
- 8、 Discharge shut-off valve Ø42(1-5/8")
- 9、 Oil cooler connection Ø10
- 10、 Non return valve
- 11、 High pressure gas 1/8"NPT
- 12、 Discharge temperature sensor 1/8"NPT PTC140°C