

SRS10 single-stage hermetic Compressor

srmtecgroup.com/products/compressors/srs-10/

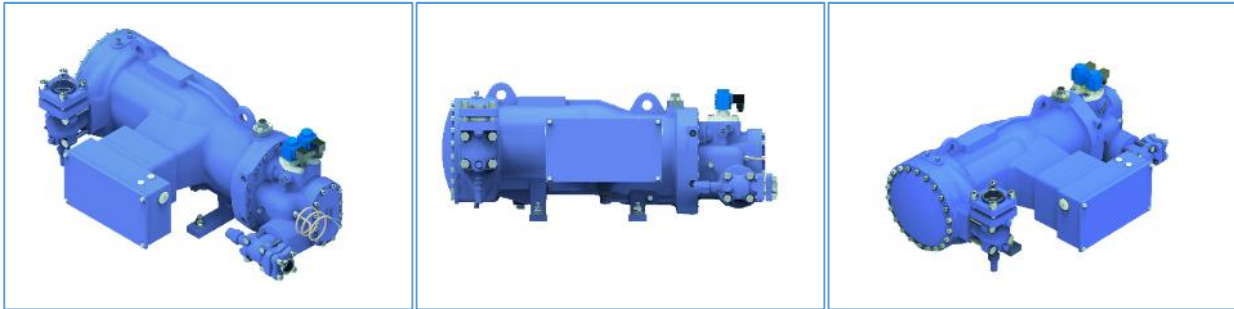

SRS10 Series		
Model	SRS 10SH	SRS 10LH
Displacement @2960 rpm [m3/h]	140	168
Displacement @3600 rpm [m3/h]	168	202
Capacity Control	Steps 50% - 75% - 100%	
Max. rpm	3600	
E-motor (kW)	45	
Vi Control	Fixed	
Vi adjustment range	4,2	
Rotation, onto compressor shaft	counter-clockwise, looking at the compressor input shaft	
Non-return valve discharge side	Yes	
Suction inlet diameter [mm]	OD 60,3; DN50	
Discharge outlet diameter [mm]	OD 42,4; DN32	
Eco connection [mm]	OD 26; DN20	
Design pressure	28 bar	
Length [mm]	890	890
Width [mm]	490	490
Height [mm]	390	390
Weight [kg]	240	260

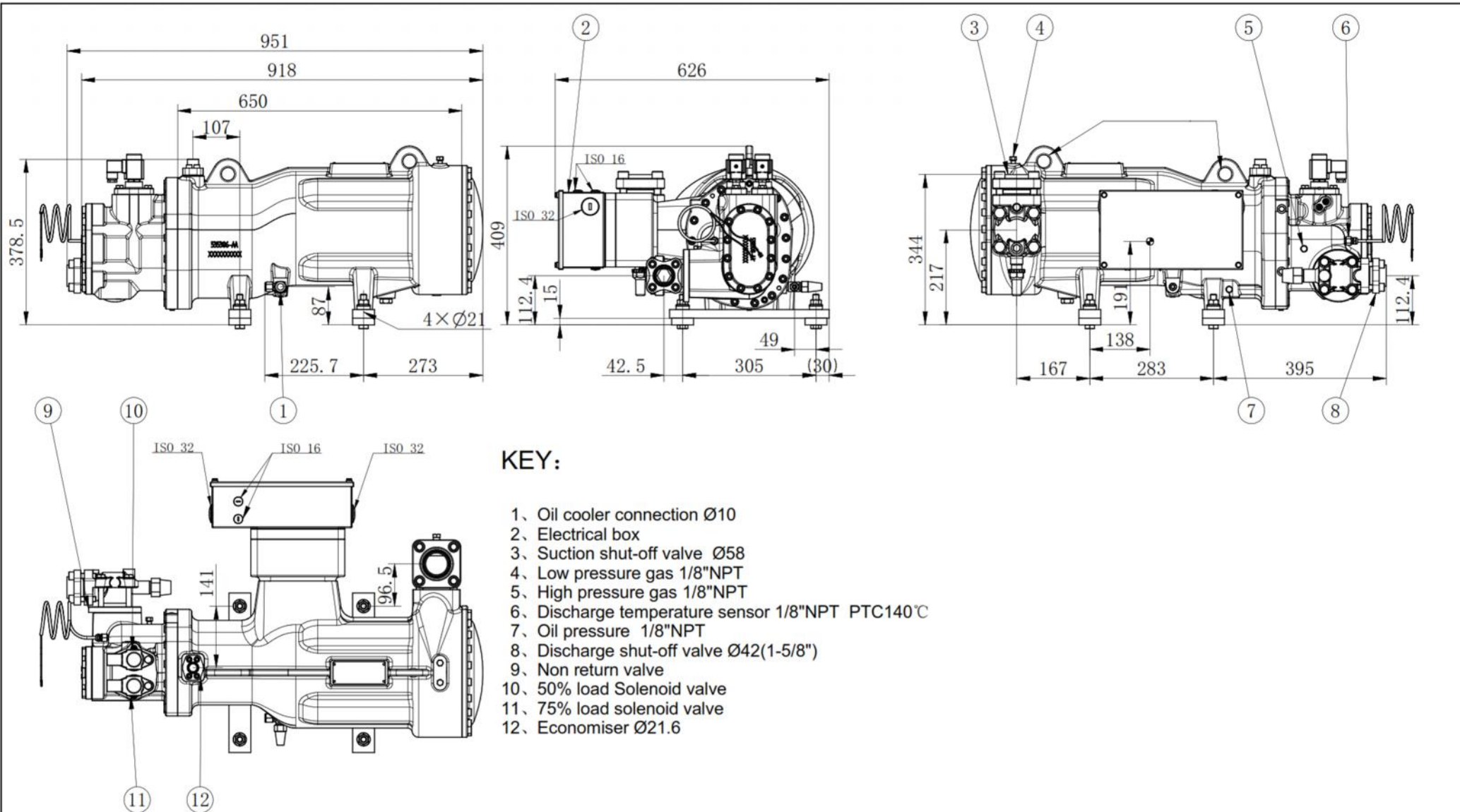

KEY:

- 1. Oil cooler connection Ø10
- 2. Electrical box
- 3. Suction shut-off valve Ø58
- 4. Low pressure gas 1/8"NPT
- 5. High pressure gas 1/8"NPT
- 6. Discharge temperature sensor 1/8"NPT PTC140°C
- 7. Oil pressure 1/8"NPT
- 8. Discharge shut-off valve Ø42(1-5/8")
- 9. Non return valve
- 10. 50% load Solenoid valve
- 11. 75% load solenoid valve
- 12. Economiser Ø21.6