

SRS16 single-stage semi-hermetic Compressor

srmtecgroup.com/products/compressors/srs-16/

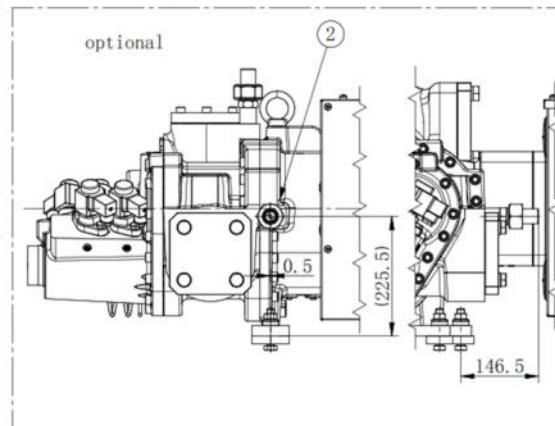

SRS16 Series			
Model	SRS-16SM	SRS-16MM	SRS-16LM
Displacement @2960 rpm [m3/h]	420	450	500
Displacement @3600 rpm [m3/h]	504	540	600
Capacity Control	Steps 25%- 50%- 75%- 100%		
Max. rpm	3600		
E-motor (kW)	134		
Vi Control	Manual/Auto		
Vi adjustment range	2,9 - 4,2		
Rotation, onto compressor shaft	counter-clockwise, looking at the compressor input shaft		
Non-return valve discharge side	Yes		
Suction inlet diameter [mm]	OD114,3; DN100		
Discharge outlet diameter [mm]	OD76; DN65		
Eco connection [mm]	OD 26; DN25		
Design pressure	28 bar		
Length [mm]	1348	1348	1348
Width [mm]	798	798	798
Height [mm]	627	627	627
Weight [kg]	670	675	680

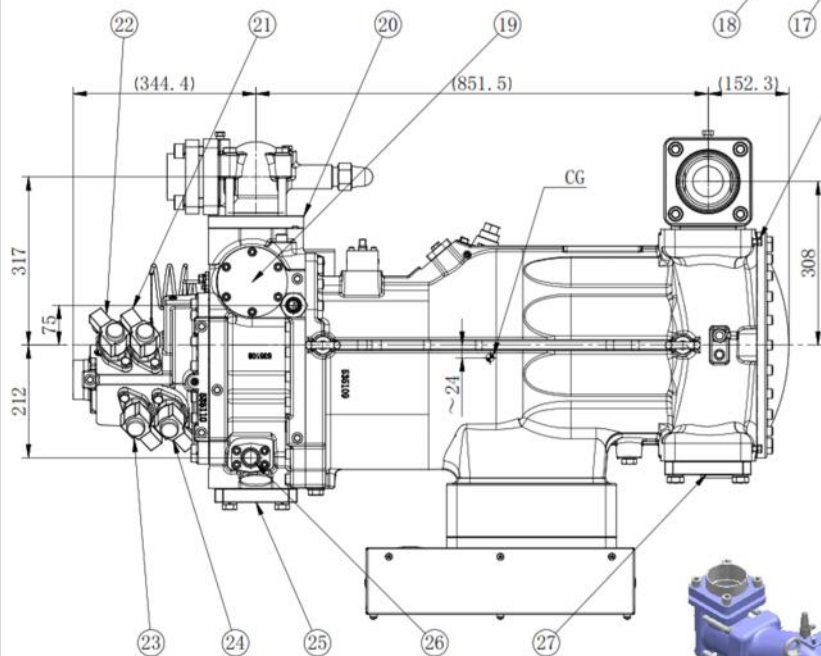
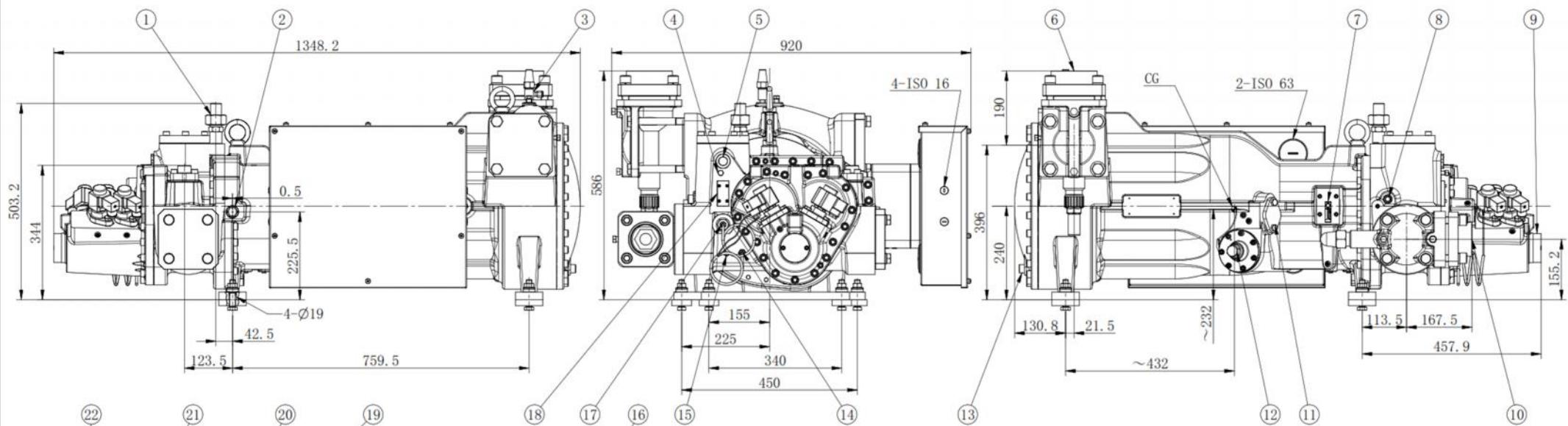

KEY:

- 1、 Oil inlet connection Ø28/M26x1.5
- 2、 Plug M26x1.5/Liquid connection Ø28 (optional)
- 3、 Suction liquid injection port Ø6.1(The Tube Inserting)
- 4、 Oil pressure 1/8"NPT
- 5、 Oil level sight glass
- 6、 Suction shut-off valve Ø110 (Ø108)
- 7、 Oil flow switch
- 8、 Filter oil drain
- 9、 Coverplate/Displacement sensor (optional)
- 10、 Discharge shut-off valve Ø77(Ø76)
- 11、 Coverplate/Vi solenoid valve (optional)
- 12、 Manual Vi control device/ Automatic Vi control device (optional)
- 13、 Suction oil drain
- 14、 Discharge temperature sensor PTC140°C
- 15、 High pressure gas 1/4"SAE-Flare
- 16、 Low pressure gas 1/4"SAE-Flare
- 17、 Oil channel on/off sensor
- 18、 Coverplate
- 19、 Built-in oil filter
- 20、 Non return valve
- 21、 Load solenoid valve
- 22、 25% load solenoid valve
- 23、 50% load solenoid valve
- 24、 75% load solenoid valve
- 25、 Alternative outlet port
- 26、 ECO inlet port Ø34
- 27、 Alternative inlet port

