

SRM41 single-stage open Compressor

srmtecgroup.com/products/compressors/srm-41/

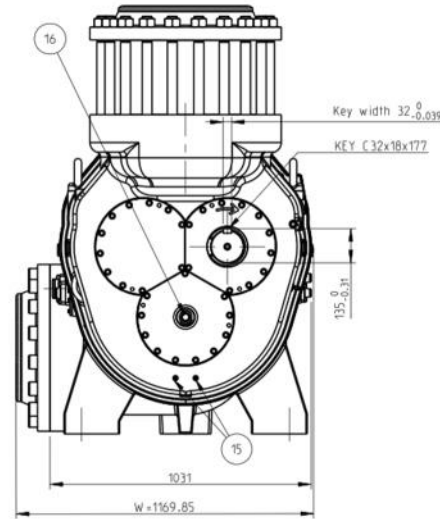

SRM 41 Series			
Model	SRM-41S	SRM-41M	SRM-41L
Displacement @2960 rpm [m3/h]	6800	8400	10000
Displacement @3600 rpm [m3/h]	8270	10200	12160
Capacity Control	Step-less 10% - 100%		
Max. rpm	3000		
Vi Control	Manual adjustable / Auto Vi		
Vi adjustment range	2.0/3.5/5.0		
Rotation, onto compressor shaft	counter-clockwise		
Non-return valve suction side	built-in		
Suction inlet diameter [mm]	500	500	500
Discharge outlet diameter [mm]	400	400	400
Eco connection [mm]	65	65	65
Design pressure	28 bar		
Length [mm]	2484	2683	2852
Width [mm]	1169	1205	1162
Height [mm]	1691	1694	1690
Weight [kg]	6090	6420	6750

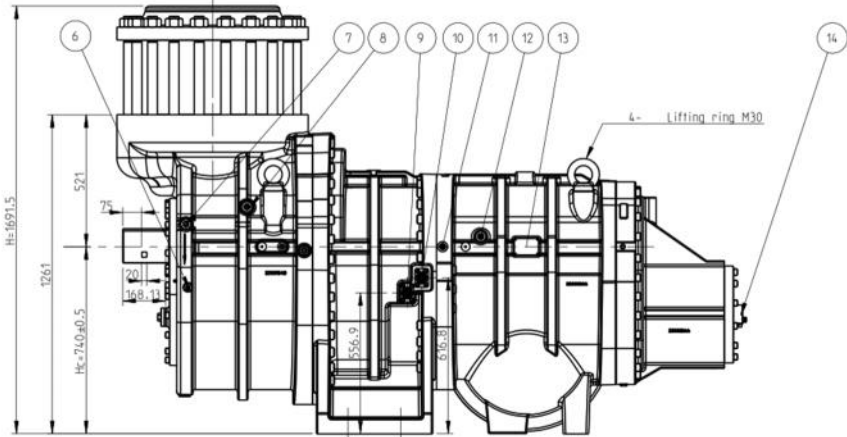
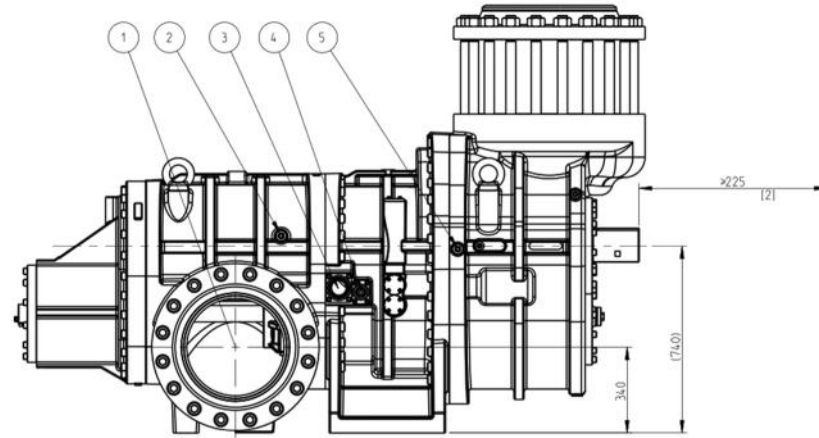
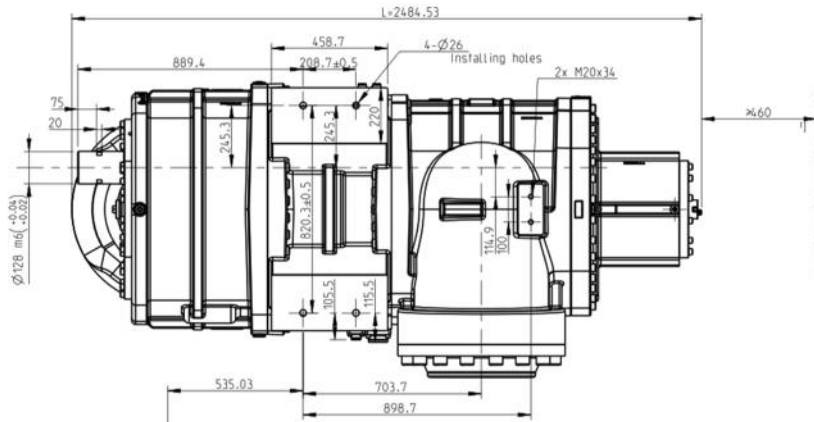

name	unit	parameter	remarks
Refrigerant	/	ammonia/freon	
Design Pressure	barA	28	
Theoretical displacement	m ³ /h	6800 full-load	2960rpm
	rpm	8160 full-load	4200rpm
Rotation Direction	/	clockwise	Seen from the shaft end

comments
 [1] It is remain maintenance space of capacity sensor.
 [2] It is remain maintenance space of shaft seal
 [3] The parts with "*" must connect to pipe.

Notes:

- *1. Discharge port DN40/PN40, W NØ426*11(metric) or Ø406.4*11(inch)
- *2. Injection port of bearing lubrication NPT3/4
- *3. Economiser DN65/PN40, if use, W NØ76*4(metric or inch); if not, don't connect pipeline.
- *4. Rotor oil injection port DN50/PN40, W NØ57*3.5(metric) or Ø60.3*3.2(inch)
- *5. Injection port of bearing lubrication NPT3/4
- *6. Oil drainage connector of shaft seal Ø6
- *7. Injection port of bearing and shaft seal NPT1/2
- *8. Injection port of balancing piston NPT1/2
- *9. Rotor oil injection port DN32/PN40, W NØ38*3(metric) or Ø42.4*2.9(inch)
- *10. Rotor oil injection port DN32/PN40, W NØ38*3(metric) or Ø42.4*2.9(inch)
- *11. Injection port of bearing lubrication NPT3/4
- *12. Injection port of bearing lubrication NPT3/4
- *13. Name plate
- *14. Capacity displacement sensor. Non-explosion proof. 5 pins M12 connector; Exploding proof. PG9, Ø5-7mm.
- *15. Oil release port NPT1/4
- *16. Internal V.I. regulator, Hexagon S=27mm..
- *17. Suction port DN500/PN40, W NØ530x14.2(metric) or Ø508*14.2(inch)
- *18. Oil supply and return. Deloading NPT1/2
- *19. Oil supply and return. Loading NPT1/2

DESIGNED	CHECKED	APPROVED	SRMTEC
SIGNED			SRM-41S
DATE			Outline Drawing
MARK	MATERIAL	WEIGHT/KG	SCALE
		0030.0	1:10
SUM 1, PAGE 1			VER
			AC

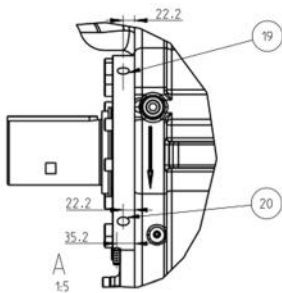
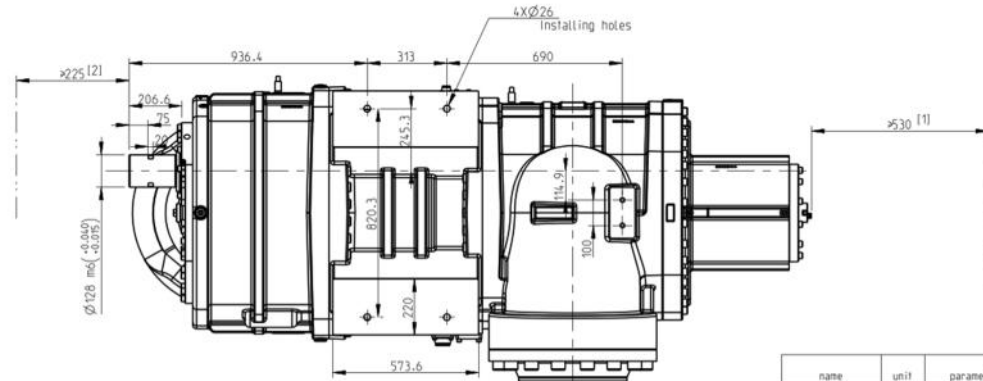
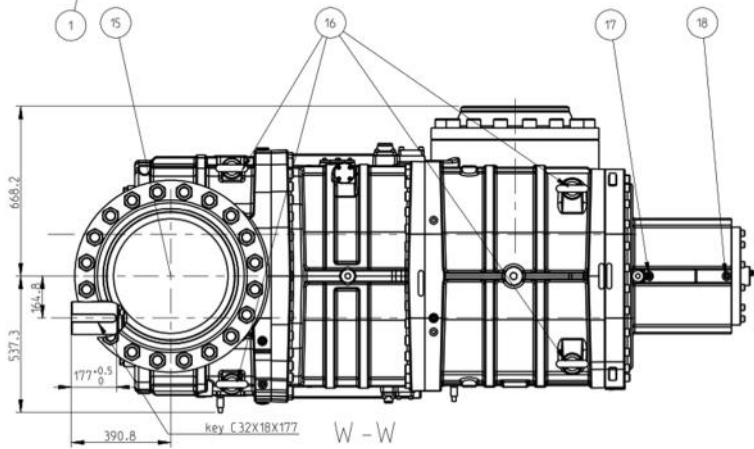
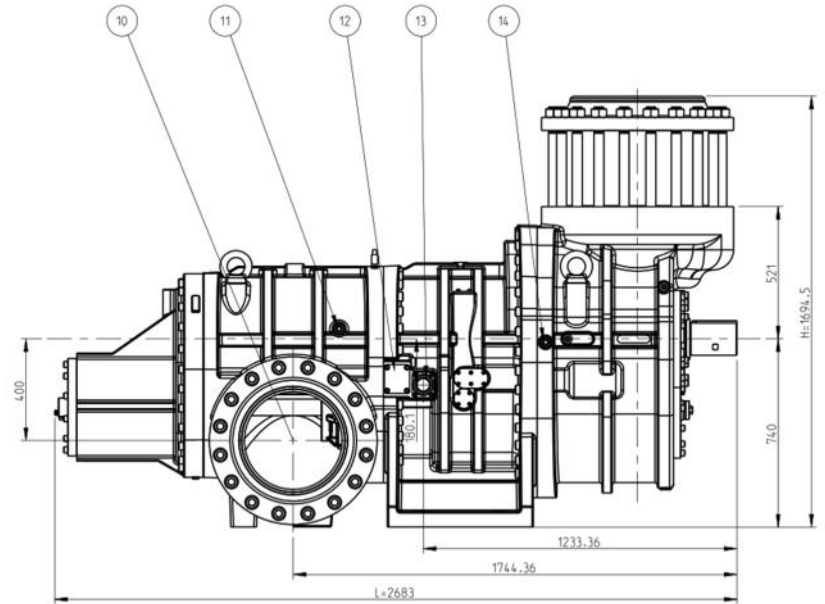
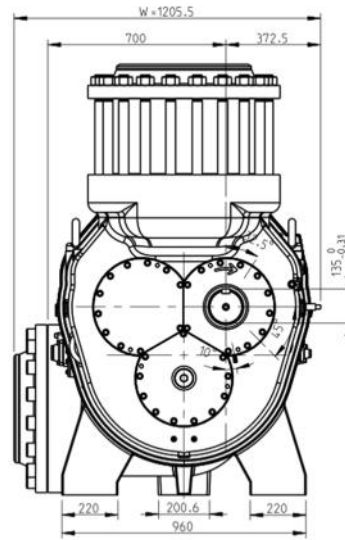
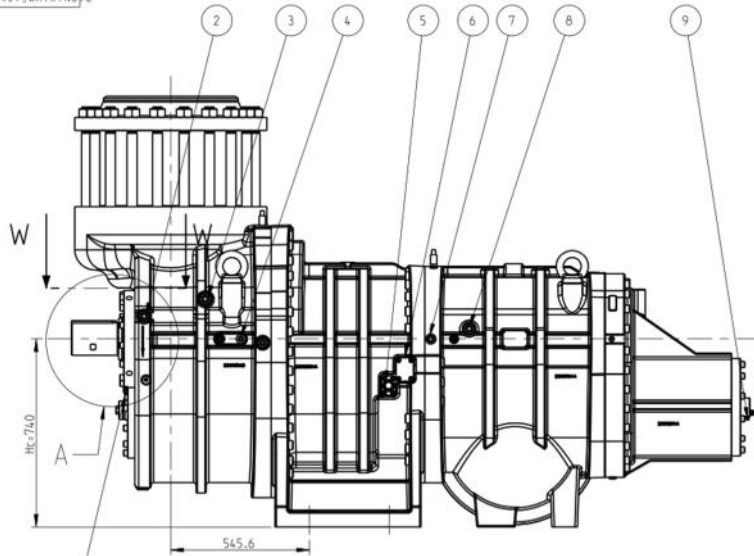

KEY

- 1.Oil drainage connector of shaft seal $\varnothing 6$
- 2.Oil injection port of Seal and Bearing NPT3/4
- 3.Oil injection port of Balancing Piston NPT3/4
- 4.Testing hole NPT1/2
- 5.Oil Injection port of rotor,Flange $\varnothing 32 \times 3$
- 6.Liquid Injection port .if use,Flange $\varnothing 38 \times 3$
- 7.Oil injection port of bearing NPT3/4
- 8.Oil injection port of bearing NPT3/4
- 9.Capacity displacemnt sensor.Non-explosion proof:5 pins M12 connector; Explosing proof:PG9.Ø5-7mm.
- 10.Discharge port, DN400/PN40,Flange $\varnothing 426 \times 11$
- 11.Oil injection port of bearing NPT3/4
- 12.Economizer.if use,Flange $\varnothing 76 \times 4$
- 13.Oil Injection port of rotor,Flange $\varnothing 57 \times 3.5$
- 14.Oil injection port of bearing NPT3/4
- 15.Suction port, DN500/PN40,Flange $\varnothing 530 \times 14.2$
- 16.Lifting ring M36
- 17.Oil injection port of Cap.Valve Unload NPT1/2
- 18.Oil injection port of Cap.Valve Load NPT1/2
- 19.Connection For Barrier/BufferOutlet
- 20.Connection For Barrier/BufferInlet

name	unit	parameter	remarks
Refrigerant	/	ammonia/freon	
Design Pressure	barA	28	
Theoretical displacement	m ³ /h	full-load	2960rpm
	rpm	full-load	3600rpm
Rotation Direction	/	clockwise	See from the shaft end

comments

- [1] It is remain maintenance space of capacity sensor.
- [2] It is remain maintenance space of shaft seal
- [3] The parts with "*" must connect to pipe.

DESIGNED		CHECKED		APPROVED		SRMTEC
SIGND	DATE					
MARK	MATERIAL	WEIGHT/KG	SCALE	SRM-41MMC-U1-EX Outline Drawing		
		6420.0	1:20	010401	VER	AC
SSW 1, PAGE 1						

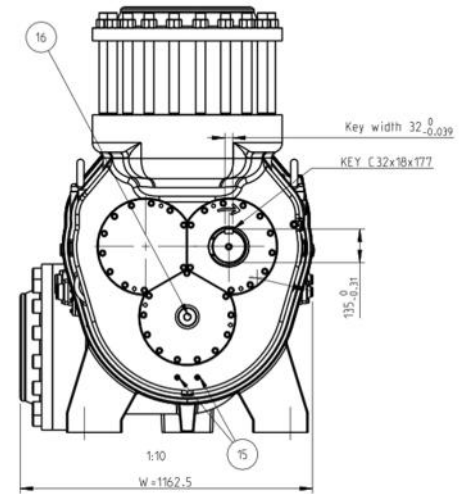
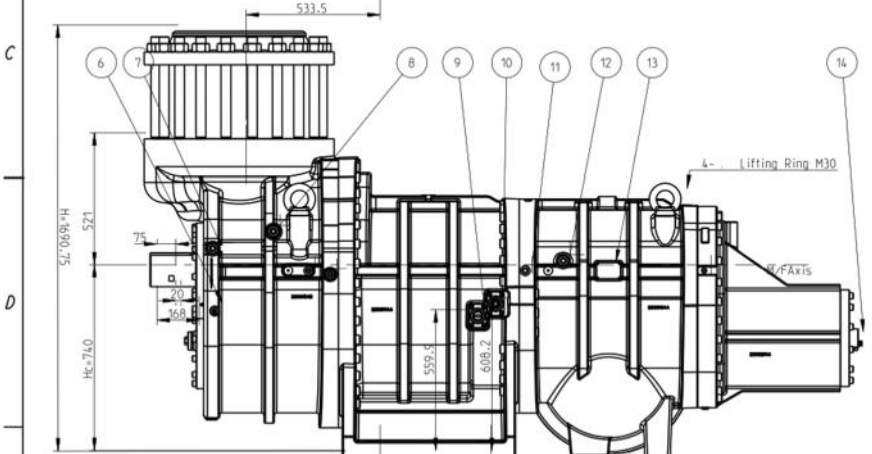
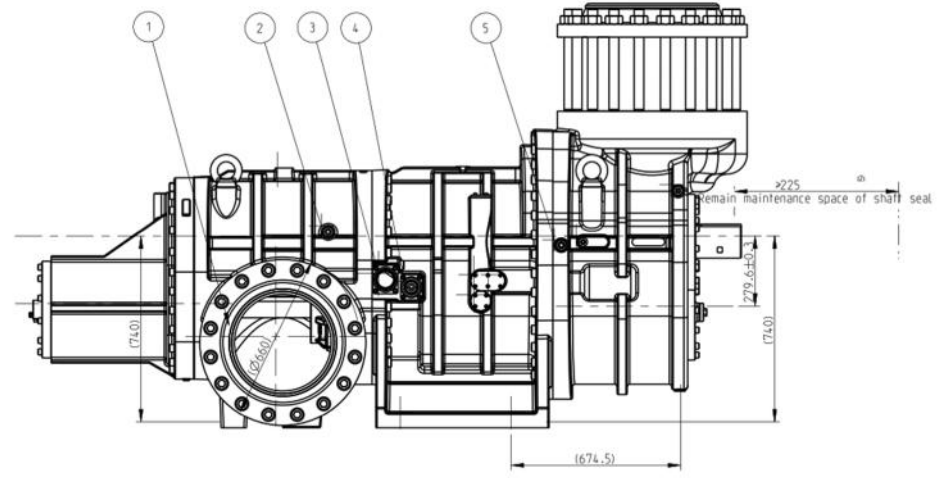
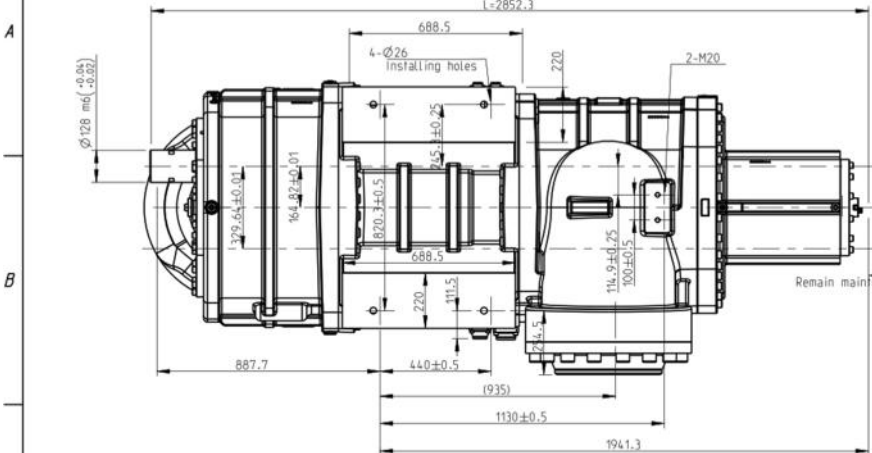

name	unit	parameter	remarks
Refrigerant	/	ammonia/freon	
Design Pressure	barA	28	
Theoretical displacement	m ³ /h	10000l full-load	2960rpm
	rpm	12000 full-load	3600rpm
Rotation Direction	/	clockwise	See from the shaft extension end

- comments
- [1] is remain maintenance space of capacity sensor.
 - [2] is remain maintenance space of shaft seal
 - [3] The parts with "*" must connect to pipe.

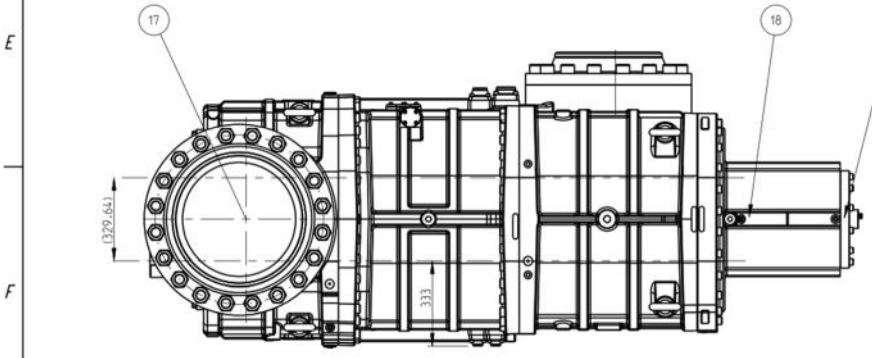

- Notes:
- *1-Discharge port DN40/PN4.0, W.NØ426*11(metric) or Ø406.4*11(inch)
 - *2-Injection port of bearing Lubrication NPT3/4
 - *3-Economiser DN65/PN4.0, if use, W.NØ76*4(metric or inch); if not, don't connect pipeline.
 - *4-Rotor oil injection port DN50/PN4.0, W.NØ57*3.5(metric) or Ø60.3*3.2(inch)
 - *5-Injection port of bearing lubrication NPT3/4
 - *6-Oil drainage connector of shaft seal Ø6
 - *7-Injection port of bearing and shaft seal NPT1/2
 - *8-Injection port of balancing piston NPT1/2
 - *9-Rotor oil injection port DN32/PN4.0, W.NØ38*3(metric) or Ø42.4*2.9(inch)
 - *10-Rotor oil injection port DN32/PN4.0, W.NØ38*3(metric) or Ø42.4*2.9(inch)
 - *11-Injection port of bearing lubrication NPT3/4
 - *12-Injection port of bearing lubrication NPT3/4
 - *13-Name plate
 - *14-Capacity displacement sensor.Non-explosion proof.5 pins M12 connector; Explosing proof:PG9,Ø5-7mm.
 - *15-Oil release port NPT1/4
 - *16-Internal VI regulator.Hexagon.S=27mm..
 - *17-Suction port DN50/PN4.0, W.NØ530x14.2(metric) or Ø508*14.2(inch)
 - *18-Oil supply and return,Deloading NPT1/2
 - *19-Oil supply and return>Loading NPT1/2

SIGNED	DESIGNED	CHECKED	APPROVED	SRMTEC
DATE	MATERIAL	WEIGHTING	SCALE	SRM-41LMA
		6750.0	1:10	Outline Drawing
SUM PAGE 1				010399
				VER AC

